

# WIND 3150

## Installation and Operation Manual

English .....	2
Français .....	16
Español .....	29
Português .....	42



# NAVMAN



### **FCC Statement**

Note: This equipment has been tested and found to comply with the limits for a Class B digital device, pursuant to Part 15 of the FCC Rules. These limits are designed to provide reasonable protection against harmful interference in a normal installation. This equipment generates, uses and can radiate radio frequency energy and, if not installed and used in accordance with the instructions, may cause harmful interference to radio communications. However, there is no guarantee that interference will not occur in a particular installation. If this equipment does cause harmful interference to radio or television reception, which can be determined by turning the equipment off and on, the user is encouraged to try to correct the interference by one or more of the following measures:

- Reorient or relocate the receiving antenna.
- Increase the separation between the equipment and receiver.
- Connect the equipment into an output on a circuit different from that to which the receiver is connected.
- Consult the dealer or an experienced technician for help.
- A shielded cable must be used when connecting a peripheral to the serial ports.

# Contents

<b>1 Introduction</b> .....	<b>4</b>
<b>2 Operation</b> .....	<b>5</b>
2-1 Turn on and off .....	5
2-2 The keys .....	5
2-3 Set backlight for display and keys .....	5
2-4 Alarm .....	5
2-5 Simulate mode .....	5
2-6 How the unit measures wind speed and angle .....	5
2-7 Key reference .....	6
<b>3 Display apparent or true wind speed and angle</b> .....	<b>7</b>
<b>4 Display wind angle</b> .....	<b>8</b>
4-1 Set wind damping .....	8
<b>5 Display wind speed</b> .....	<b>8</b>
5-1 Set wind speed units .....	8
<b>6 Display maximum wind speed</b> .....	<b>9</b>
6-1 Reset maximum wind speed .....	9
<b>7 Display VMG (velocity made good)</b> .....	<b>9</b>
<b>8 Calibrate wind angle and speed</b> .....	<b>9</b>
8-1 Calibrate wind angle .....	9
8-2 Calibrate wind speed .....	9
<b>9 Systems of several instruments</b> .....	<b>10</b>
9-1 NavBus .....	10
9-2 NMEA .....	10
<b>10 WIND 3150 hardware</b> .....	<b>11</b>
10-1 What comes with your WIND 3150 .....	11
10-2 Other parts required .....	11
10-3 Accessories .....	11
<b>11 Installation and setup</b> .....	<b>12</b>
11-1 Installation .....	12
11-2 Setup .....	14
11-3 Resetting to factory defaults .....	14
<b>Appendix A - Specifications</b> .....	<b>15</b>
<b>Appendix B - Troubleshooting</b> .....	<b>15</b>
<b>Appendix C - How to contact us</b> .....	<b>55</b>

## Units

The factory default units are knots. To change these units, please refer to section 5-1 of this manual.

# 1 Introduction

The WIND 3150 displays:

- Apparent wind angle and wind speed.
- True wind angle and wind speed (requires data from a boat speed instrument).
- Maximum wind speed.
- VMG, the component of boat speed parallel to the wind (requires data from a boat speed instrument).

An installed WIND 3150 has two parts:

- The display unit.
- The masthead unit, which has devices for measuring wind speed and wind angle.

The unit is powered from the boat's power supply.

The WIND 3150 is part of the NAVMAN 3100 family of instruments, which includes instruments for speed, depth, wind and repeaters. These instruments can be connected together to form an integrated data system (see section 9).

For maximum benefit, please read this manual carefully before installation and use.

## Cleaning and maintenance

Clean the display unit with a damp cloth or mild detergent. Avoid abrasive cleaners, petrol or other solvents.

## The WIND 3150 display unit

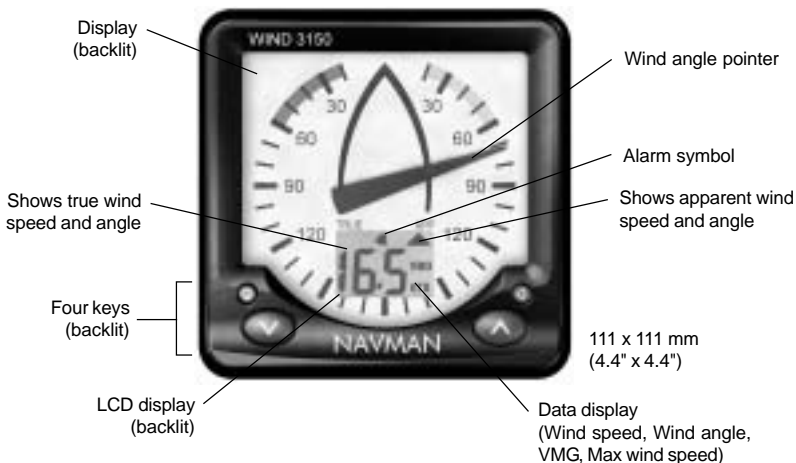

**Note:** If an item displays as dashes (—) then it means that the value is not available. For example, true wind values are not available if the WIND 3150 is not connected to a boat speed instrument.

## Important

It is the owner's sole responsibility to install and use the instrument and masthead unit in a manner that will not cause accidents, personal injury or property damage. The user of this product is solely responsible for observing safe boating practices.

NAVMAN NZ LIMITED DISCLAIMS ALL LIABILITY FOR ANY USE OF THIS PRODUCT IN A WAY THAT MAY CAUSE ACCIDENTS, DAMAGE OR THAT MAY VIOLATE THE LAW.

This manual represents the WIND 3150 as at the time of printing. Navman NZ Limited reserves the right to make changes to specifications without notice.

Copyright © 2002 Navman NZ Limited, New Zealand. All rights reserved. NAVMAN is a registered trademark of Navman NZ Limited.





## 2 Operation

### 2-1 Turn on and off

Turn the unit on and off with the auxiliary power switch on the boat. The unit does not have its own power switch. When the unit is turned on, the pointer rotates once as the unit performs a self-calibration. When the unit is turned off, any settings you have made are retained.



If the word **SIM** flashes on the LCD display then the unit is in simulate mode (see section 2-5).

### 2-2 The keys

The unit has four keys, labelled , ,  and . In this manual:

- **Press** means to push the key for less than a second.
- **Hold** means to hold the key down for the specified time or until the display changes.
- **Press one key + another key** means to push both keys together.

### 2-3 Set backlight for display and keys

You can set the backlight to one of four brightness levels or off (the key backlight does not turn off). Press  once to display the current backlight level, press  again to change the level:



Backlight level 2 (flashes)





### 2-4 Alarm

The WIND 3150 will sound an alarm if the alarm is turned on and the apparent wind speed exceeds the alarm value. To turn the alarm on or off and set the alarm value:

- 1 Press  to display the Wind Speed Alarm screen:



Alarm is on  
Wind alarm speed 50 kts (flashes)

- 2 To change the alarm value, press  or .
- 3 To turn the alarm on or off, press .
- 4 Press .

When the alarm sounds, the internal beeper sounds, the  symbol on the display flashes and any external beepers or lights operate.

Press any key to mute the alarm. The alarm stays muted until the wind speed drops below the alarm value. The alarm will sound again if the wind speed exceeds the alarm value again.

### 2-5 Simulate mode

Simulate mode allows you to become familiar with the unit off the water. In Simulate mode, the WIND 3150 functions normally except that the data from the masthead unit is ignored and the unit generates this data internally. The word **SIM** flashes on the LCD display.

To turn Simulate mode on or off:

- 1 Turn the power off.
- 2 Hold down  while you turn the power on.

### 2-6 How the unit measures wind speed and angle

The masthead unit has a rotor with three wind cups which spins as the wind moves past the boat. The masthead unit measures how fast the wind cups are spinning to calculate the wind speed.

The masthead unit has a vane which points in the angle that the wind is coming from. The masthead unit electronically senses the direction the vane is pointing.

#### Masthead unit



## 2-7 Key reference

### Turn power on

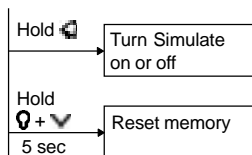

### Normal operation

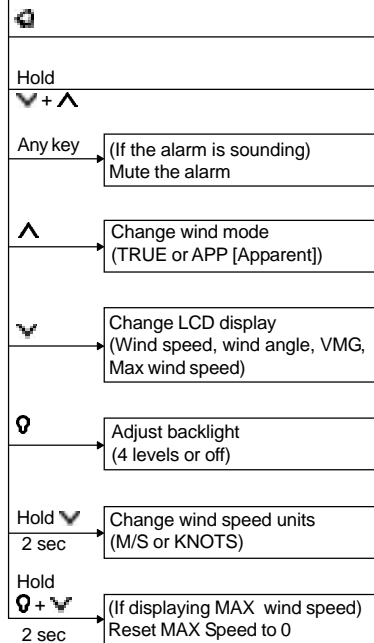

### Set alarm

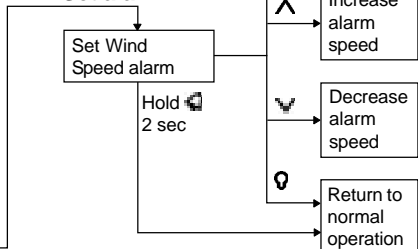

### Setup

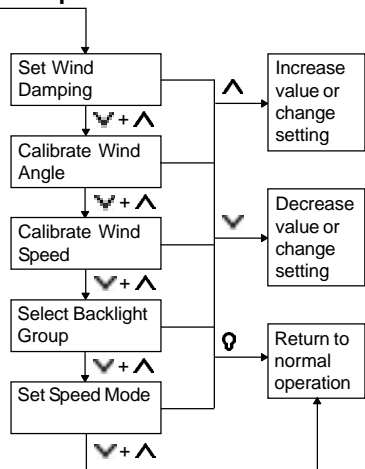

### 3 Display apparent or true wind speed and angle

Apparent wind speed and angle are the values measured by the masthead unit on the boat. True wind speed and angle are calculated values that allow for the relative speed of the boat.

If the boat is moving, then the apparent wind speed is different to the true wind speed and the apparent wind angle is different to the true wind angle, as shown below.

If the WIND 3150 is not connected to a speed instrument, then the unit always displays apparent

wind speed and angle. If the WIND 3150 is connected to a boat speed instrument, press **▲** to display apparent or true wind speed and angle:

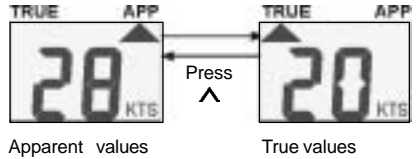

Boat is at rest. Apparent wind speed equals true wind speed and apparent wind angle equals true wind angle:

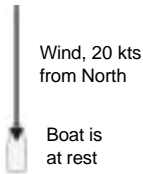

Boat moving upwind. Apparent wind speed is greater than true wind speed and apparent wind angle is closer to dead ahead than true wind angle:

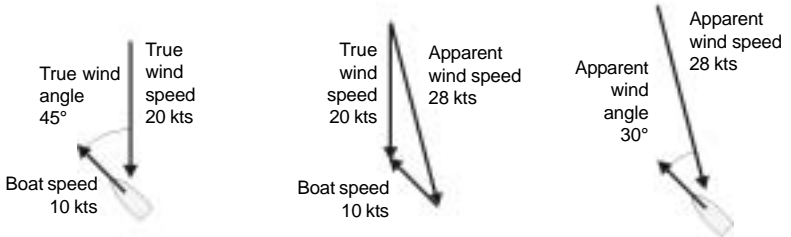

Boat moving downwind. Apparent wind speed is less than true wind speed and apparent wind angle is closer to dead ahead than true wind angle:

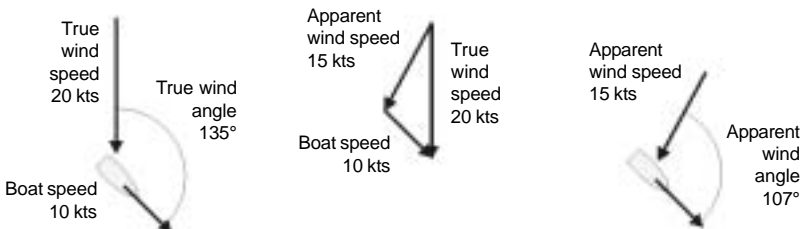

## 4 Display wind angle

The pointer shows wind angle in degrees (0 to 180° port or starboard). To display the numeric wind angle as well, press  until the degrees symbol is displayed, for example:

Wind from 30° to starboard

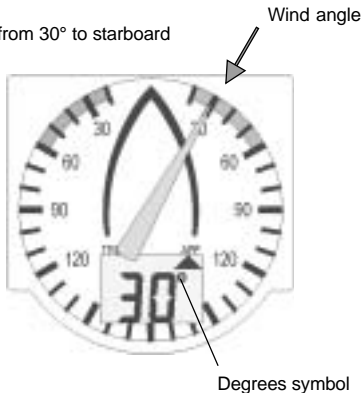

Wind from 120° to port

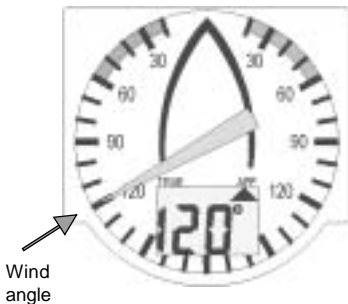

If the WIND 3150 is connected to a boat speed instrument, press  to display **TRUE** or **APP** (apparent) wind angle (see section 3).

### 4-1 Set wind damping

Wind turbulence, gusts and mast motion cause the measured wind angle and speed to fluctuate. To give stable readings, the WIND 3150 calculates wind angle and speed by measuring the values several times and averaging the measurements. The wind damping value ranges from 1 to 5:

- A lower value averages measurements over a shorter period of time. This gives the most accurate readings but has the most fluctuations.
- A higher value averages measurements over a longer period of time. This gives the most stable readings but will ignore some rapid changes.



**Note:** Set the damping to the lowest value which gives stable readings. Values of 1, 2, 3, 4 and 5 average measurements over a time period of 6, 12, 18, 24 and 30 seconds respectively.

To set the damping:

- 1 Press  +  to display the Wind Damping screen:



Damping equals 3 (flashes)

- 2 Press  or  to change the damping.
- 3 Press .

## 5 Display wind speed

To display wind speed, press  until the speed is displayed, for example:



If the WIND 3150 is connected to a boat speed instrument, press  to display **TRUE** or **APP** (apparent) wind speed (see section 3).

### 5-1 Set wind speed units

To change the wind speed units to KNOTS or M/S:

- Hold  until the units change.

**Note:** VMG is always shown in knots.



## 6 Display maximum wind speed

To display maximum wind speed, press  $\nabla$  until the maximum speed is displayed, for example:



The maximum wind speed is the highest measured apparent wind speed since the maximum wind speed was reset or the unit was switched on.

### 6-1 Reset maximum wind speed

Resetting starts calculating a new maximum:

- 1 Press  $\nabla$  until MAX speed is displayed.
- 2 Hold  $\nabla$  +  $\nabla$  for two seconds.

## 7 Display VMG (velocity made good)

To display VMG, press  $\nabla$  until VMG is displayed, for example see right:

VMG (velocity made good), is the component of boat speed parallel to the wind. VMG is only available if the WIND 3150 is connected to a boat speed instrument.

**Note:** VMG is always shown in knots.



## 8 Calibrate wind angle and speed

### 8-1 Calibrate wind angle

Calibrate wind angle after installation if the masthead arm is not parallel to the centre line of the boat. If the displayed wind angle seems inaccurate, first check that the vane on the masthead unit is not damaged or corroded, then calibrate wind angle. To calibrate wind angle:

- 1 You must know what the correct apparent wind angle is. The easiest way for a boat with a motor is to travel at maximum speed when there is no wind. The correct wind angle is then from ahead, 0°.
- 2 Press  $\nabla$  +  $\blacktriangle$  several times until the Calibrate Wind Angle screen is displayed:



- 3 After two seconds, the LCD display changes to display the apparent wind angle:

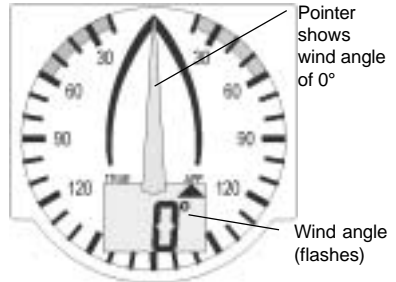

- 4 Press  $\blacktriangle$  or  $\nabla$  to change the displayed apparent wind angle to the correct value.
- 5 Press  $\nabla$ .

### 8-2 Calibrate wind speed

The unit is factory calibrated and should not normally need calibrating. If the displayed wind speed seems inaccurate, first check that the rotor on the masthead unit is not damaged or corroded, then calibrate wind speed:

- 1 You must know what the correct wind speed is.

travel at maximum speed when there is no wind; the correct wind speed is then equal to the boat speed. Find the boat speed from a speed instrument in the boat or in another boat travelling at the same speed.

- 2 Press **▼** + **▲** several times until the Calibrate Wind Speed screen is displayed:



- 3 After two seconds, the display changes to display the apparent wind speed:



- 4 Press **▲** or **▼** to change the displayed apparent wind speed to the correct value.
- 5 Press **⓪**.

## 9 Systems of several instruments

Several NAVMAN instruments can be connected together to share data. There are two ways of connecting instruments together, NavBus or NMEA.

### 9-1 NavBus

NavBus is a NAVMAN proprietary system that allows systems of multiple instruments to be built using a single set of transducers. When instruments are connected by NavBus:

- If you change the units, alarms or calibration in one instrument, then the values will automatically change in all other instruments of the same type.
- Each instrument can be assigned to a group of instruments (see section 11-2, step 3). If you change the backlight in an instrument in group 1, 2, 3 or 4 then the backlight will automatically change in the other instruments in the same group. If you change the backlight in an instrument in group 0 then no other instruments are affected.
- If an alarm sounds, you can mute it on any instrument which can display that alarm.

#### NavBus and the WIND 3150

- If the WIND 3150 does not have a masthead unit fitted then the unit will automatically take wind angle and speed readings from another instrument, via NavBus, if the data is available. For more information, refer to the *NavBus Installation and Operation Manual*.

If a masthead unit is not fitted to the unit and the corresponding external data is not available then the displayed value will be dashes (— —).

- To display true wind speed, true wind angle and VMG, the WIND 3150 must be connected to an instrument that outputs boat speed. Typical instruments that output boat speed are:
  - A GPS receiver (outputs boat speed over ground).
  - A NAVMAN SPEED 3100, which uses a paddlewheel transducer (outputs boat speed through water).

**Note:** *If there is a current, these two speeds are different.*

*You must select which type of boat speed the WIND 3150 will use (see section 11-2, step 2).*

### 9-2 NMEA

NMEA is an industry standard, but is not as flexible as NavBus as it requires dedicated connections between instruments. Wind speed and wind angle are output by the WIND 3150 and can be read and displayed by the NAVMAN REPEAT 3100 or other NMEA instruments. The WIND 3150 can receive NMEA boat speed data:

- RMC or VTG from any compatible GPS instrument (speed over ground).
- VHW from any compatible instrument with a paddlewheel speed transducer (speed through water).

**Note:** *You must select which type of boat speed the WIND 3150 will use (see section 11-2, step 2).*

# 10 WIND 3150 hardware

## 10-1 What comes with your WIND 3150

### Standard configuration:

- WIND 3150 unit with protective cover.
- Masthead unit.
- 30 m (98 ft) Masthead cable.
- Masthead cable junction box.
- Warranty card.
- Mounting template.
- This *Installation and Operation Manual*.



## 10-2 Other parts required

One or more 3100 series instruments will be connected to the boat 12 V DC power supply via:

- An accessory switch to turn the instruments on and off.
- A fuse. Use a 1 A fuse for between one and five instruments.



Optional external beepers or lights can be fitted. The WIND 3150 output is switched to ground, 30 V DC and 250 mA maximum. If the beepers and lights require more than 250 mA, fit a relay.



For systems of several instruments, wiring and connectors are required (see the *NavBus Installation and Operation Manual*).

In order to display true wind speed and angle and VMG, the WIND 3150 must be connected to an instrument that outputs boat speed (see section 9).

The WIND 3150 is usually used with the supplied masthead unit. However, the unit can take readings from another NAVMAN wind instrument, in which case the masthead unit does not need to be fitted to this WIND 3150 (see section 9-1).

## 10-3 Accessories

These accessories and spare parts are available from your NAVMAN dealer.



Replacement  
masthead unit



Replacement  
wind cups



Replacement  
vane



NavBus junction box  
(see section 9-1)

## 11 Installation and setup

Correct installation is critical to the performance of the unit. It is vital to read this section of the manual and the documentation that comes with the other parts before starting installation.

The WIND 3150 can:

- Drive external beepers or lights for the alarm.
- Send and receive data from other NAVMAN instruments connected via NavBus. Settings for alarms, units, calibration and backlighting are shared (see section 9-1).
- Send and receive NMEA data to and from other instruments (see section 9-2).

### Warnings

The unit is waterproof from the front. Protect the rear of the unit from water, or else water might enter the breathing hole and damage the unit. The warranty does not cover damage caused by moisture or water entering the back of the unit.

The cable up the mast to the masthead unit must run in conduit.

**Ensure that any holes that you cut will not weaken the boat or the mast. If in doubt, consult a qualified boat builder or marine engineer.**

### 11-1 Installation

#### WIND 3150 display unit

- 1 Choose a location for the display unit that is:
  - Easily seen and protected from damage.
  - At least 100 mm (4") from a compass and at least 500 mm (20") from a radio or radar antenna.
  - Away from engines, fluorescent lights, and power inverters.
  - Accessible from behind; the minimum clearance required at the back is 50 mm (2") (see mounting diagram).
  - With the back of the unit protected from moisture.
- 2 The unit must mount on a flat panel which is less than 20 mm (0.75") thick. Stick the mounting template in place. Drill a 50 mm (2") fixing hole through the centre hole in the template. Note that the template allows space around the unit for the protective cover.
- 3 Remove the fixing nut from the back of the unit. Insert the back of the unit through the mounting hole. Hand tighten the fixing nut.

#### Side view of display unit mounting:

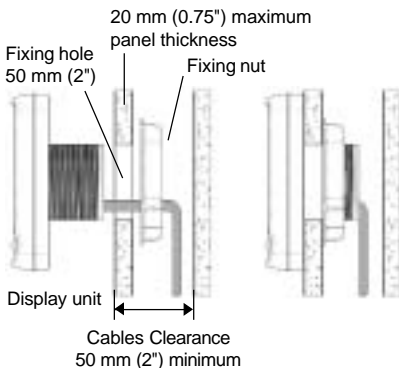

#### Masthead unit

Plan the installation. Read through these instructions before you install the masthead unit and plan where you will fit the mounting block and where you will drill the cable holes in the mast. It is usually easiest to install the masthead unit when the rig is off the boat.

- 1 The mounting block is at one end of the 30 m (98 ft) masthead cable. Fit the mounting block on top of the mast:
  - With the base of the block horizontal.
  - With the fitting for the masthead arm facing forward, parallel to the centre line to within a few degrees (if the arm does not face exactly forward, the wind angle must be calibrated, see section 8-1).

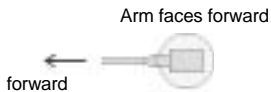

Use the self-tapping screws provided.

- 2 Drill an 8 mm (5/16") hole at the top of the mast close to the mounting block for the cable to enter the mast. Do not install the masthead cable yet.
- 3 Drill an 8 mm (5/16") hole at the bottom of the mast at a convenient place for the cable to exit the mast. You will fit the cable junction box close to this hole; it should be in a dry place and not in the bilge.
- 4 Calculate how long the cable from the masthead mounting block to the cable junction

box needs to be. Allow extra length for terminating the cable in the junction box. Cut the masthead cable to this length from the mounting block. Do not throw away the other piece of cable.

- 5 Lead the bare end of the masthead cable into the hole at the top of the mast, down the conduit in the mast and out the hole at the bottom of the mast. Fit a strain relief clamp or cable tie to the cable at the mast top. Fill both cable holes in the mast with sealant.
- 6 Feed the end of the cable through a gland on the cable junction box. Strip the cable jacket off and terminate the wires on the terminal block supplied.
- 7 Take the piece of masthead unit cable that you cut off earlier and connect the cable into the back of the WIND 3150 display unit. Run the cable between the display unit and the cable junction box:
  - Keep the cable away from other cables, engines, fluorescent lights and power inverters.
  - Secure the cable at regular intervals.
- 8 Cut the cable to length, allowing extra length for terminating the cable in the joining box. Feed the end of the cable through the other gland on the cable junction box. Strip the cable jacket off and terminate wires on the terminal block, matching the wire colours.
- 9 Screw the lid on the junction box and screw the box in place on a panel.
- 10 Fit the wind cups to the shaft on the masthead unit using the allen key supplied.
- 11 Attach the arm to the mounting block:
  - Plug the arm into the mounting block.
  - Screw the sleeve on the arm onto the mounting block.

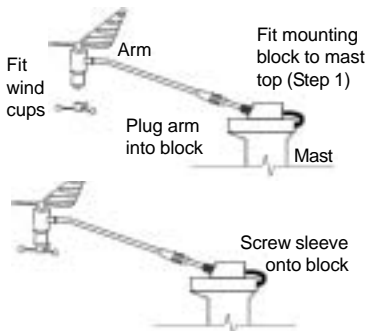

## Installed Masthead Unit

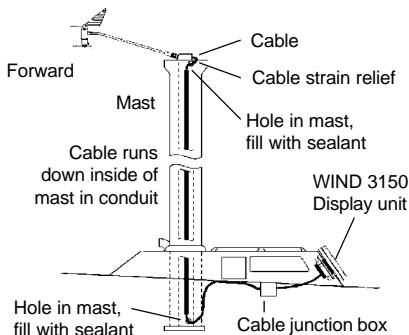

## Power/data wiring

- 1 Wire the display unit power/data cable:
  - The unit requires 12 V DC power. Fit a power switch and fuse to the power supply or power the unit from a fused auxiliary switch. The fuse should be 1 A for up to five instruments.
  - The output to external beepers and lights is switched to power negative by the WIND 3150 to sound the alarm. If the external beepers and lights require more than 250 mA DC total, fit a relay.

A single unit can be wired as shown below:

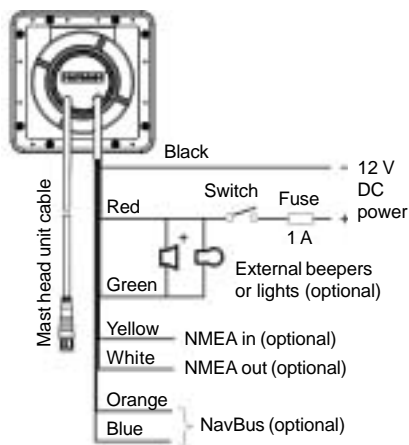

With several instruments, use the optional junction boxes to simplify wiring, as shown below:

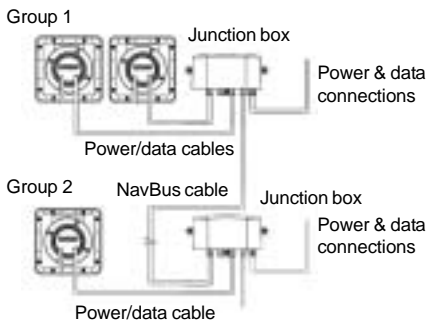

For information on how to connect NavBus and to use junction boxes, refer to the *NavBus Installation and Operation Manual*.

- 2 Tape or cover any unused wires or connectors to protect them from water and keep them from shorting together.

## 11-2 Setup

- 1 Take the boat for a trial run to check that all the instruments work correctly.



- 2 To display VMG and true wind speed and angle, the WIND 3150 must be connected to a compatible instrument that outputs boat speed. If the WIND 3150 is connected to an

instrument that outputs speed through water and to an instrument that outputs speed over ground, then you can select which the WIND 3150 will use (see section 9):

- i Press  $\nabla + \blacktriangle$  several times until the Speed Mode screen is displayed:



- ii After two seconds, the mode is displayed, flashing.  $\blacktriangle$  (Speed over ground) or  $\blacktriangle$  (boat speed through water) flashes.
  - iii Press  $\blacktriangle$  or  $\nabla$  to change the mode to  $\blacktriangle$  or  $\blacktriangle$ .
  - iv Press  $\odot$ .
- 3 If the unit is part of a system of 3100 series instruments connected by NavBus, set the backlight group number (see section 9-1):
    - i Press  $\nabla + \blacktriangle$  several times until the Backlight Group screen is displayed:
    - ii Press  $\blacktriangle$  or  $\nabla$  to set the backlight group number.
    - iii Press  $\odot$ .
  - 4 Set:
    - The wind speed units (see section 5-1) .
  - 5 Calibrate if required:
    - Wind angle (see section 8-1).
    - Wind speed (see section 8-2).

## 11-3 Resetting to factory defaults

All settings may be reset to the manufacturer's

Wind speed units .....	knots
Wind damping .....	2
Wind speed alarm .....	Off
SIMULATE mode .....	Off
Backlight Level .....	0
Backlight Group .....	1
Boat Speed Input .....	$\blacktriangle$

default settings (see below).

To reset to factory defaults:

- 1 Turn the power off.
- 2 Hold down  $\odot + \nabla$  while you turn the power on and continue to hold the keys down for at least five seconds.

# Appendix A - Specifications

## Physical

- Case size 111 mm (4.4") square.
- LCD display 27 mm (1.1") wide, 18 mm (0.7") high; twisted nematic.
- LCD digits 14 mm (0.55") high.
- Four operator keys, laser etched.
- Backlighting for display and keys, amber, four levels and off (the key backlight does not turn off).
- Operating temperature 0 to 50°C (32 to 122°F).
- Power cable length 1 m (3.25 ft).
- Masthead unit cable length 30 m (99 ft).

## Electrical

- Power supply 10.5 to 16.5 V DC, 20 mA without backlighting, 140 mA with full backlighting and transducer.
- External beeper or light output, switched to power negative to turn on the beepers or lights, 30 V DC and 250 mA maximum.

## Wind

- Wind angle, true and apparent: Range 0 to 180°, port or starboard.
- Wind speed, true and apparent: Range 0 to 199 knots (0 to 102 m/s).
- Maximum apparent wind speed.
- Apparent wind speed alarm.

## Calibration

- Wind speed and wind angle can be calibrated.

# Appendix B - Troubleshooting

This troubleshooting guide assumes that you have read and understood this manual.

It is possible in many cases to solve difficulties without having to send the unit back to the manufacturer for repair. Please follow this troubleshooting section before contacting the nearest NAVMAN dealer.

There are no user serviceable parts. Specialized methods and testing equipment are required to ensure that the unit is reassembled correctly and is waterproof. Repairs to the unit must only be carried out by a service centre approved by Navman NZ Limited. Users who service the unit themselves will void the warranty.

More information can be found on our website: [www.navman.com](http://www.navman.com)

## 1 Unit will not turn on:

- a Fuse blown or circuit breaker tripped.
- b Battery voltage is outside the range 10.5 to 16.5 V DC.
- c Power/data cable damaged.

## Interfaces

- NavBus connection to other NAVMAN instruments.
- NMEA 0183 outputs: MWV, VPW; inputs RMC, VHW, VTG.

## Standards compliance

- EMC compliance
  - USA (FCC):** Part 15 Class B.
  - Europe (CE):** EN50081-1, EN50082-1
  - New Zealand and Australia (C Tick):** AS-NZS 3548.
- Environment: IP66 from front when correctly mounted.

## Power/data cable wires

Wire	Signal
Red	Power positive, 12 V DC, 140 mA maximum
Black	Power negative, NMEA common
Green	External beeper or light out, switched to power negative, 30 V DC and 250 mA max.
Orange	NavBus +
Blue	NavBus -
White	NMEA out
Yellow	NMEA in

## 2 Wind speed or angle reading wrong or erratic:

- a Masthead unit is damaged, fouled or corroded.
- b Wind speed calibration is incorrect (see section 8-2).
- c Wind angle calibration is incorrect (see section 8-1).
- d Masthead unit cable unplugged or damaged.
- e Interference from electrical noise. Review installation.

## 3 The word SIM flashes on the LCD display or the values displayed are unexpected:

- a Unit is in simulate mode (see section 2-5).

## 4 The display fogs:

- a Moist air has entered the breathing tube at the rear of the unit. Air the boat or run unit with backlight fully on.
- b Water has entered the breathing tube. Return unit for service.

**NORTH AMERICA**

NAVMAN USA INC.  
18 Pine St. Ext.  
Nashua, NH 03060.  
Ph: +1 603 577 9600  
e-mail: sales@navmanusa.com

**OCEANIA**

New Zealand  
Absolute Marine Ltd.  
Unit B, 138 Harris Road,  
East Tamaki, Auckland.  
Ph: +64 9 273 9273  
e-mail:  
navman@absolutemarine.co.nz

Australia  
NAVMAN AUSTRALIA PTY  
Limited  
Unit 6 / 5-13 Parsons St,  
Rozelle, NSW 2039, Australia.  
Ph: +61 2 9818 8382  
e-mail: sales@navman.com.au

**SOUTH AMERICA**

Argentina  
Costanera UNO S.A.  
Av Presidente R Castillo y  
Calle 13  
1425 Buenos Aires, Argentina.  
Ph: +54 11 4312 4545  
e-mail:  
purchase@costanerauno.com.ar  
Website:  
www.costanerauno.ar

Brazil  
REALMARINE  
Estrada do Joa 3862,  
CEP2611-020,  
Barra da Tijuca, Rio de Janeiro,  
Brazil.  
Ph: +55 21 2483 9700  
e-mail:  
vendas@marinedepot.com.br  
Equinautic Com Imp Exp de  
Equip Nauticos Ltda.  
Av. Diario de Noticias 1997 CEP  
90810-080, Bairro Cristal, Porto  
Alegre - RS, Brasil.  
Ph: +55 51 3242 9972  
Fax: +55 51 3241 1134  
e-mail:  
equinautic@equinautic.com.br

**ASIA**

China  
Peaceful Marine Electronics Co. Ltd.  
Hong Kong, Guangzhou,  
Shanghai, Qindao, Dalian.  
E210, Huang Hua Gang Ke Mao  
Street, 81 Xian Lie Zhong Road,  
510070 Guangzhou, China.  
Ph: +86 20 3869 8784  
e-mail:  
sales@peaceful-marine.com  
Website:  
www.peaceful-marine.com

Korea  
Kumhomarine Technology Co., Ltd.  
#604-842, 2F, 1118-15,  
Janglim1-Dong, Saha-Gu  
Busan, Korea  
Ph: +82 51 293 8589  
e-mail: info@kumhomarine.com  
Website:  
www.kumhomarine.com

Singapore and Malaysia  
RIQ PTE Ltd.  
Block 3007, Ubi Road 1  
#02-440, Singapore 408701  
Ph: +65 6741 3723  
HP: +65 9679 5903  
e-mail: riq@postone.com

Taiwan  
Seafirst International  
Corporation  
No.281, Hou-An Road  
Chien-Chen Dist.  
Kaohsiung, Taiwan  
R.O.C.  
Ph: +886 7 831 2688  
e-mail:  
seafirst@seed.net.tw

Thailand  
Thong Electronics (Thailand)  
Company Ltd.  
923/588 Thaprong Road,  
Mahachai,  
Muang, Samutsakhon 74000,  
Thailand.  
Ph: +66 34 411 919  
e-mail: thonge@cscoms.com

Vietnam  
Haidang Co. Ltd.  
16A/ALE, Ba thang hai St.  
District 10, Hochiminh City.  
Ph: +84 8 86321 59  
e-mail:  
sales@haidangvn.com  
Website: www.haidangvn.com

**MIDDLE EAST**

Lebanon and Syria  
Letro, Balco Stores,  
Moutran Street, Tripoli  
VIA Beirut.  
Ph: +961 6 624512  
e-mail: balco@cyberia.net.lb  
United Arab Emirates  
Kuwait, Oman, Iran & Saudi Arabia  
Abdullah Moh'd Ibrahim  
Trading, opp Creak Rd.  
Baniyas Road, Dubai.  
Ph: +971 4 229 1195  
e-mail: mksq99@email.com

**AFRICA**

South Africa  
Pertec (Pty) Ltd Coastal,  
Division No.16 Paarden Eiland Rd.  
Paarden Eiland, 7405  
Postal Address: PO Box 527,  
Paarden Eiland 7420  
Cape Town, South Africa.  
Ph: +27 21 511 5055  
e-mail: info@kfa.co.za

**EUROPE**

France, Belgium and  
Switzerland  
PLASTIMO INTERNATIONAL  
15, rue Ingénieur Verrière,  
BP435,  
56325 Lorient Cedex.  
Ph: +33 2 97 87 36 36  
e-mail: plastimo@plastimo.fr  
Website: www.plastimo.fr

Germany  
PLASTIMO DEUTSCHLAND  
15, rue Ingénieur Verrière  
BP435  
56325 Lorient Cedex.  
Ph: +49 6105 92 10 09  
+49 6105 92 10 10  
+49 6105 92 10 12  
e-mail:  
plastimo.international@plastimo.fr  
Website: www.plastimo.de

Italy  
PLASTIMO ITALIA  
Nuova Rade spa, Via del Pontasso 5  
I-16015 CASELLA SCRIVIA (GE).  
Ph: +39 1096 8011  
e-mail: info@nuovarade.com  
Website: www.plastimo.it

Holland  
PLASTIMO HOLLAND BV.  
Industrieweg 4-6,  
2871 RP SCHOONHOVEN.  
Ph: +31 182 320 522  
e-mail: info@plastimo.nl  
Website: www.plastimo.nl  
United Kingdom  
PLASTIMO Mfg. UK Ltd.  
School Lane - Chandlers Ford  
Industrial Estate,  
EASTLEIGH - HANTS SO53 ADG.  
Ph: +44 23 8026 3311  
e-mail: sales@plastimo.co.uk  
Website: www.plastimo.co.uk

Sweden, Denmark or Finland  
PLASTIMO NORDIC AB.  
Box 28 - Lundenvägen 2,  
47321 HENAN.  
Ph: +46 304 360 60  
e-mail: info@plastimo.se  
Website: www.plastimo.se

Spain  
PLASTIMO ESPAÑA, S.A.  
Avenida Narcís Monturiol, 17  
08339 VILASAR DE DALT,  
(Barcelona).  
Ph: +34 93 750 75 04  
e-mail: plastimo@plastimo.es  
Website: www.plastimo.es

Portugal  
PLASTIMO PORTUGAL  
Avenida de Industria Nº40  
1300-299 Lisbon  
Ph: +351 21 362 04 57  
e-mail:  
plastimo@siroco-nautica.pt

Other countries in Europe  
PLASTIMO INTERNATIONAL  
15, rue Ingénieur Verrière  
BP435  
56325 Lorient Cedex, France.  
Ph: +33 2 97 87 36 59  
e-mail:  
plastimo.international@plastimo.fr  
Website: www.plastimo.com

REST OF WORLD /  
MANUFACTURERS  
Navman NZ Limited  
13-17 Kawana St. Northcote.  
P.O. Box 68 155 Newton,  
Auckland, New Zealand.  
Ph: +64 9 481 0500  
e-mail:  
marine.sales@navman.com  
Website:  
www.navman.com



Made in New Zealand  
MN000199B

Lon 174° 44.535'E

Lat 36° 48.404'S

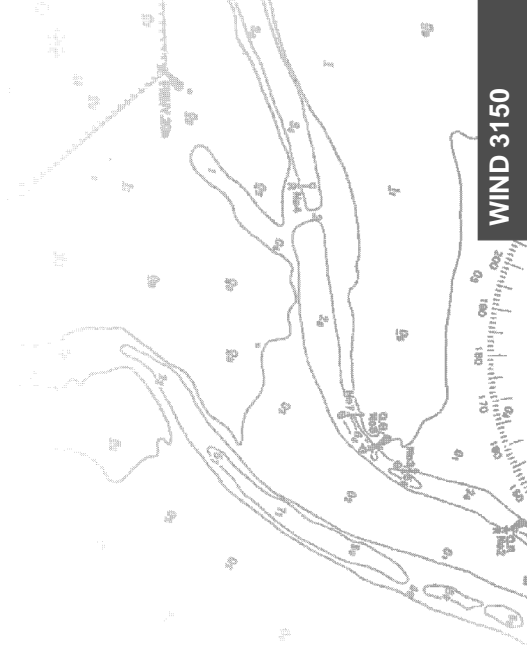

WIND 3150

# NAVMAN

