

# WIND 3100

## Installation and Operation Manual

English .....	2
Français .....	17
Español .....	32
Português .....	47
Chinese .....	62



# NAVMAN



### **FCC Statement**

Note: This equipment has been tested and found to comply with the limits for a Class B digital device, pursuant to Part 15 of the FCC Rules. These limits are designed to provide reasonable protection against harmful interference in a normal installation. This equipment generates, uses and can radiate radio frequency energy and, if not installed and used in accordance with the instructions, may cause harmful interference to radio communications. However, there is no guarantee that interference will not occur in a particular installation. If this equipment does cause harmful interference to radio or television reception, which can be determined by turning the equipment off and on, the user is encouraged to try to correct the interference by one or more of the following measures:

- Reorient or relocate the receiving antenna.
- Increase the separation between the equipment and receiver.
- Connect the equipment into an output on a circuit different from that to which the receiver is connected.
- Consult the dealer or an experienced technician for help.
- A shielded cable must be used when connecting a peripheral to the serial ports.

# Contents

<b>1 Introduction</b>	<b>4</b>
<b>2 Operation</b>	<b>5</b>
2-1 Turn on and off	5
2-2 Basic operation	5
2-3 Alarms	5
2-4 Simulate mode	5
2-5 Key reference	6
2-6 Apparent and true wind speed and direction	7
<b>3 Wind direction</b>	<b>8</b>
3-1 Wind direction display	8
3-2 Set wind direction pointer type	8
3-3 Set wind direction damping	8
3-4 Calibrate wind alignment	9
<b>4 Wind speed, VMG</b>	<b>9</b>
4-1 Set wind speed units	9
4-2 Reset maximum wind speed	9
4-3 Set wind speed alarm	9
4-4 Calibrate wind speed	9
<b>5 Steer to wind</b>	<b>10</b>
5-1 Set required steering angle	11
5-2 Set steering resolution	11
<b>6 Systems of several instruments</b>	<b>11</b>
6-1 NavBus	11
6-2 NMEA	11
<b>7 WIND 3100 hardware</b>	<b>12</b>
7-1 What comes with your WIND 3100	12
7-2 Other parts required	12
7-3 Accessories	12
<b>8 Installation and setup</b>	<b>13</b>
8-1 Installation	13
8-2 Setup	15
8-3 Resetting to factory defaults	15
<b>Appendix A - Specifications</b>	<b>16</b>
<b>Appendix B - Troubleshooting</b>	<b>16</b>
<b>Appendix C - How to contact us</b>	<b>79</b>

## Units

The factory default units are knots. To change these units, please refer to section 4-1 of this manual.

# 1 Introduction

The WIND 3100 displays:

- Apparent wind direction and wind speed.
- True wind direction and wind speed (requires data from a speed instrument).
- Maximum wind speed.
- Steering directions to sail at a constant angle to the wind (steer to wind).
- VMG, the component of boat speed parallel to the wind (requires data from a speed instrument).

An installed WIND 3100 has two parts:

- The display unit.
- The masthead unit, which has devices for measuring wind speed and wind direction.

The unit is powered from the boat's power supply.

The WIND 3100 is part of the NAVMAN family of instruments, which includes instruments for speed, depth, wind and repeaters. These instruments can

be connected together to form an integrated data system (see section 6).

For maximum benefit, please read this manual carefully before installation and use.

## How it measures wind speed

The masthead unit has a rotor with three windcups which spins as the wind moves past the boat. The masthead unit measures how fast the rotor is spinning to calculate the wind speed.

## How it measures wind direction

The masthead unit has a windvane which points in the direction that the wind is coming from. The masthead unit electronically senses the direction the windvane is pointing.

## Cleaning and maintenance

Clean the display unit with a damp cloth or mild detergent. Avoid abrasive cleaners, petrol or other solvents.

## The WIND 3100 display unit



### Important

It is the owner's sole responsibility to install and use the instrument and masthead unit in a manner that will not cause accidents, personal injury or property damage. The user of this product is solely responsible for observing safe boating practices.

NAVMAN NZ LIMITED DISCLAIMS ALL LIABILITY FOR ANY USE OF THIS PRODUCT IN A WAY THAT MAY CAUSE ACCIDENTS, DAMAGE OR THAT MAY VIOLATE THE LAW.

This manual represents the WIND 3100 as at the time of printing. Navman NZ Limited reserves the right to make changes to specifications without notice.

Copyright © 2002 Navman NZ Limited, New Zealand, All rights reserved. NAVMAN is a registered trademark of Navman NZ Limited.

## 2 Operation





### 2-1 Turn on and off

Turn the unit on and off with the auxiliary power switch on the boat. The unit does not have its own power switch. When you turn it off, any settings you have made are retained.

If the word SIM flashes at the top, right of the display, then the unit is in simulate mode (see section 2-4).



### 2-2 Basic operation

#### The keys

The unit has four keys, labelled    and . In this manual:

- **Press** means to push the key for less than a second.
- **Hold** for two seconds means to hold the key down for two seconds or more.
- **Press one key + another key** means to push both keys together.

#### Set backlight for screen and keys

You can set the backlight to one of four brightness levels or off (the key backlight does not turn off). Press  once to display the current backlight level, press  again to change the level:



Backlight level 2

#### Change the items displayed

If an item displays as dashes (— —) then it means that the value is not available. For example true wind values are not available if the WIND 3100 is not connected to a speed instrument.

The top part of the screen displays wind direction and the bottom part displays a speed.

Press  one or more times to select:

- True wind direction and speed (only available if the WIND 3100 is connected to a speed instrument, for example the SPEED 3100 or a NAVMAN GPS).
- Apparent wind direction and speed.
- Steer to wind (see section 5).

Press  one or more times to change the speed value displayed in the bottom part of the screen (see section 4):

- Wind speed, apparent or true.
- Maximum apparent wind speed.
- VMG, the component of boat speed parallel to the wind (only available if the WIND 3100 is connected to an instrument with a speed output, for example the SPEED 3100 or a NAVMAN GPS).

### 2-3 Alarm

The WIND 3100 can be set to sound an alarm when the apparent wind speed exceeds the alarm value (see section 4-3). When the alarm sounds, the internal beeper sounds, the  symbol on the display flashes and any external beepers or lights operate.

Press  to mute the alarm. The alarm stays muted until the wind speed drops below the alarm value. The alarm will sound again if the wind speed exceeds the alarm value again.

### 2-4 Simulate mode

Simulate mode allows you to become familiar with the unit off the water. In Simulate mode, the WIND 3100 functions normally except that the data from the masthead unit is ignored and the unit generates this data internally. The word SIM flashes at the top, right corner of the screen.

To turn Simulate mode on or off:

- 1 Turn the power off.
- 2 Hold down  while you turn the power on.

## 2-5 Key reference

### Turn power on

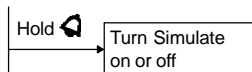

### Normal operation

Hold 2 sec

+

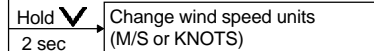
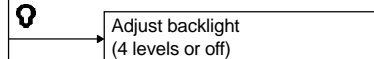
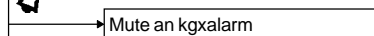
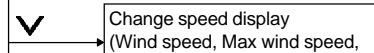
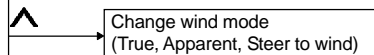

+ (If displaying Steer to Wind)

### Set steering angle

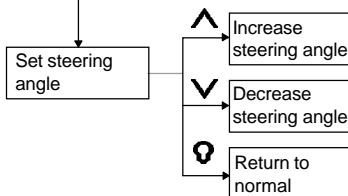

### Set alarm

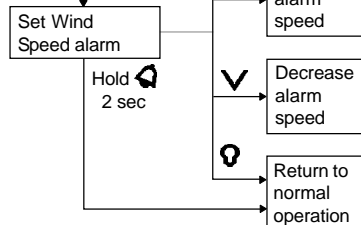

### Setup

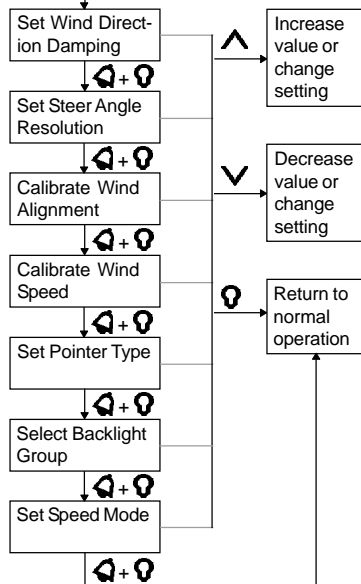

## 2-6 Apparent and true wind speed and direction

Apparent wind speed and direction are the values measured by the mast head unit on the boat. True wind speed and direction are calculated values that allow for boat speed.

If the boat is moving, then the apparent wind speed is different to the true wind speed and the apparent wind direction is different to the true wind direction, as shown below.

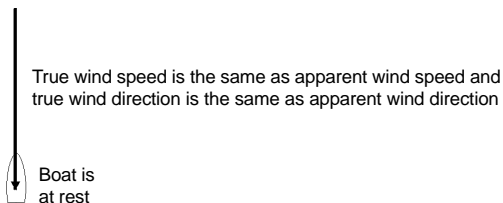

Boat moving upwind. Apparent wind speed is greater than true wind speed and apparent wind direction is closer to dead ahead than true wind direction

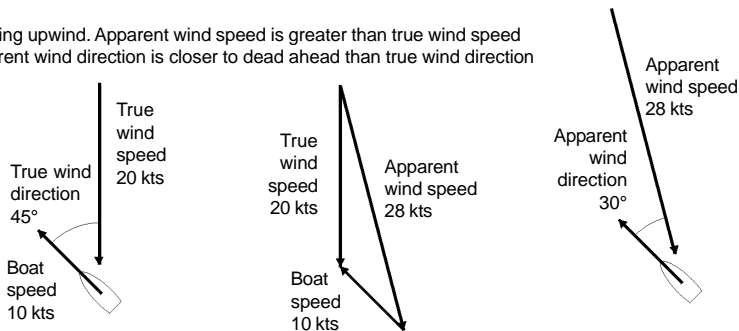

Boat moving downwind. Apparent wind speed is less than true wind speed and apparent wind direction is closer to dead ahead than true wind direction

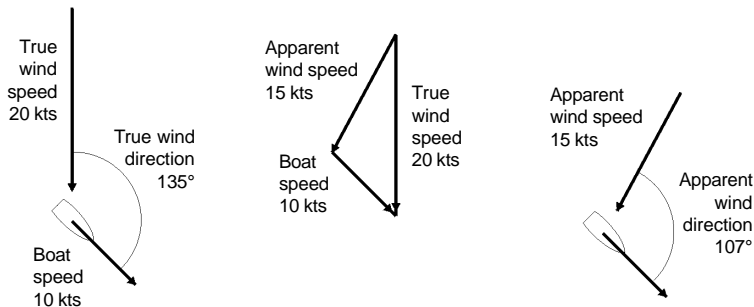

## 3 Wind direction

### 3-1 Wind direction display

To display wind direction, press  $\wedge$  one or more times, until TRUE (true wind direction) or APP (apparent wind direction) is displayed. True wind direction is only displayed if the WIND 3100 is connected to a speed instrument.

The wind direction is displayed in degrees (0 to 180° port or starboard) and by the pointer (see right).

### 3-2 Set wind direction pointer type

The wind direction pointer can be set to one of five types (see right). Type 1 is the default.

- Types 1, 2 and 3 simulate wind vanes, and have a black spot in the centre. The thinner part points to where the wind is coming from.
- Types 4 and 5 point to where the wind is coming from.

To set the pointer type:

- 1 Press  $\square + \circ$  several times until the Pointer Type screen is displayed:



Pointer type 1

- 2 Press  $\wedge$  or  $\vee$  to set the pointer type.
- 3 Press  $\circ$ .

### 3-3 Set wind direction damping

Wind turbulence, gusts and mast motion cause the wind direction to fluctuate. To give a stable reading, the WIND 3100 calculates the wind direction by measuring the direction several times and averaging the measurements. The wind direction damping value ranges from 1 to 5:

- A lower value averages readings over a shorter period of time. This gives the most accurate direction but has the most fluctuations.
- A higher value averages readings over a longer period of time. This gives the most stable direction but will ignore some true changes in direction.

**Note** : The damping affects the numeric wind direction, not the pointer. Set the wind direction damping to the lowest value which gives a stable numeric wind direction. Values of 1, 2, 3, 4 and 5 average readings over a time period of 6, 12, 18, 24 and 30 seconds respectively.

To set the damping:

Wind from 30° to starboard, pointer type 1

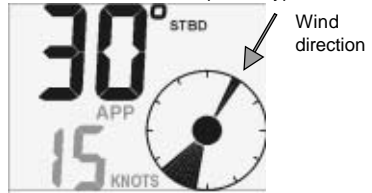

Wind from 30° to port, pointer type 2

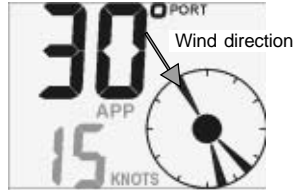

Wind from 150° to port, pointer type 3



Wind from 30° to starboard, pointer type 4

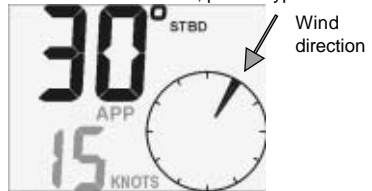

Wind from 120° to starboard, pointer type 5

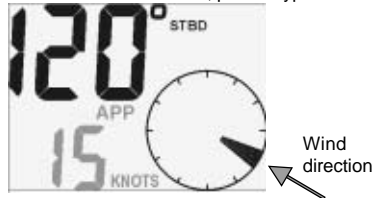



- 1 Press **Q** + **V** to display the Wind Direction Damping screen:



Damping equals 3

- 2 Press **^** or **v** to change the damping.
- 3 Press **Q**.

### 3-4 Calibrate wind alignment

You will need to calibrate the wind alignment if you believe that the displayed wind direction is inaccurate or, at installation, if the masthead arm is not parallel to the centre line of the boat:

- 1 You must know what the correct wind direction

is. The easiest way for a boat with a motor is to travel at maximum speed when there is no wind. The correct wind direction is then from ahead, 0°.

- 2 Press **Q** + **V** several times until the Calibrate Wind Alignment screen is displayed:



Wind direction is 5° to starboard

- 3 Press **^** or **v** to change the displayed wind direction to the correct value.
- 4 Press **Q**.

## 4 Wind speed, VMG

The WIND 3100 can display one of three speeds in the bottom part of the screen. Press **v** one or more times to select:

- **WIND SPEED:** The wind speed, apparent or true (see section 3).
- **MAX SPEED:** The maximum apparent wind speed since MAX SPEED was reset or the unit was switched on.
- **VMG:** The component of boat speed parallel to the wind.

True wind speed and VMG are only displayed if the WIND 3100 is connected to a speed instrument or a NAVMAN GPS.

### 4-1 Set wind speed units

The wind speed units can be selected to be KNOTS or M/S:

- Hold **v** until the units change.

**Note:** VMG is always shown in knots.

### 4-2 Reset maximum wind speed

Resetting starts calculating a new maximum:

- 1 Press **v** until MAX speed is displayed.
- 2 Hold **Q** + **v** for two seconds.

### 4-3 Set wind speed alarm

The wind speed alarm sounds if the alarm is turned on and the apparent wind speed becomes equal to or more than the wind speed alarm value. If the alarm sounds, press **Q** to mute it.

To set the alarm value or turn the alarm on or off:



Wind speed value 50 kts  
Alarm is On

- 1 Hold **Q** for two seconds to display the Wind Speed Alarm screen:
- 2 To change the alarm value, press **^** or **v**.
- 3 To turn the alarm on or off, press **Q**.
- 4 Press **Q**.

### 4-4 Calibrate wind speed

The unit is factory calibrated and should not normally need calibrating, however you should calibrate it if you believe that the displayed wind speed is inaccurate:

- 1 You must know what the correct wind speed is. The easiest way for a boat with a motor is to travel at maximum speed when there is no wind; the correct wind speed is then equal to the boat speed. Find the boat speed from a speed instrument in the boat or in another boat travelling at the same speed.

- 2 Press **Q**+**V** several times until the Calibrate Wind Speed screen is displayed (see right).
- 3 Press **^** or **v** to change the displayed wind speed to the correct value.
- 4 Press **V**.



Wind speed

## 5 Steer to wind

The steer to wind function gives steering instructions to sail at a constant angle to the apparent wind. The WIND 3100 automatically calculates the correct instructions for port or starboard tacks.

To start steering to wind, press **^** until STEER is displayed. The display shows:

- 1 The required steering angle to the apparent wind (to set the required steering angle, see section 5-1).
- 2 A direction arrow showing which way to steer to reach the required steering angle.
- 3 The steering error (the difference between the required steering angle and the actual steering angle) is shown on the circular display:

- The top two segments are always on
- The greater the steering error, the more segments turn on

The steering resolution determines how many segments turn on. The number of segments that turn on is the steering error divided by the steering resolution (to set the steering resolution, see section 5-2).

- If the boat should steer to port, then segments to the right of centre turn on
- If the boat should steer to starboard, then segments to the left of centre turn on.

### Steer to wind examples

The required steering angle is 40° and the boat is at 30° to the apparent wind. The steering error is 10°. The boat should turn 10° to port. The steering resolution is 1° and so 10 segments of the circular display are on:

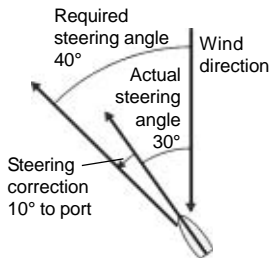

The required steering angle is 40° and the boat is at 70° to the apparent wind. The steering error is 30°. The boat should turn 30° to starboard. The steering resolution is 5° and so 6 segments of the circular display are on:

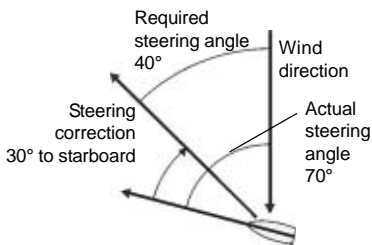

Required steering angle



Direction arrow (way to steer)  
Steering error, 10 segments are on

Required steering angle



Direction arrow (way to steer)  
Steering error, 6 segments are on

## 5-1 Set required steering angle

The required steering angle is the required angle between the boat direction and the apparent wind direction:

- 1 While steering to wind, press **V** + **^**; the required steering angle flashes:



- 2 Press **^** or **V** to change the required steering angle. The range is 0° to 150°.
- 3 Press **⏏**.

## 5-2 Set steering resolution

In steer to wind, the circular pointer shows the steering correction. The steering resolution is a number from 1 to 5 that sets the number of degrees of steering error that each segment represents (see examples on previous page).

Use a smaller steering resolution for more exact sailing.

To set the steering resolution:

- 1 Press **⏏** + **⏏** several times until the Steering Resolution screen is displayed:



- 2 Press **^** or **V** to change the resolution.
- 3 Press **⏏**.

## 6 Systems of several instruments

Several NAVMAN instruments can be connected together to share data. There are two ways of connecting instruments together, NavBus or NMEA.

### 6-1 NavBus

NavBus is a NAVMAN proprietary system that allows systems of multiple instruments to be built using a single set of transducers. When instruments are connected by NavBus:

- If you change the units, alarms or calibration in one instrument, then the values will automatically change in all other instruments of the same type.
- Each instrument can be assigned to a group of instruments (see section 1, 8-2, step 3). If you change the backlight in an instrument in group 1, 2, 3 or 4 then the backlight will automatically change in the other instruments in the same group. If you change the backlight in an instrument in group 0 then no other instruments are affected.
- If an alarm sounds, mute it by pressing **⏏** on any instrument which can display that alarm.

#### NavBus and the WIND 3100

- If the WIND 3100 does not have a masthead unit fitted then the unit will automatically take wind direction and speed readings from another instrument, via NavBus, if the data is available. For more information, refer to the NavBus Installation and Operation manual.
- If a masthead unit is not fitted to the unit and the

corresponding external data is not available then the displayed value will be dashes (— —).

- To display true wind speed, true wind direction and VMG, the WIND 3100 must be connected to an instrument that outputs boat speed. Typical instruments that output boat speed are:
  - A GPS receiver (outputs boat speed over ground).
  - A NAVMAN SPEED 3100, which uses a paddlewheel transducer (outputs boat speed through water).

**Note:** *If there is a current, these two speeds are different.*

*You must select which type of boat speed the WIND 3100 will use (see section 3.1 and 8-2, step 2).*

### 6-2 NMEA

NMEA is an industry standard, but is not as flexible as NavBus as it requires dedicated connections between instruments. Wind, speed and direction data are output by the WIND 3100 and can be read and displayed by the NAVMAN REPEAT 3100 or other NMEA instruments. The WIND 3100 can receive NMEA boat speed data:

- RMC or VTG from any compatible GPS instrument (speed over ground)
- VHW from any compatible instrument with a paddlewheel speed transducer (speed through water).

You must select which type of boat speed the WIND 3100 will use (see section 3-1, 8-2, step 2).

## 7 WIND 3100 hardware

### 7-1 What comes with your WIND 3100

#### Standard configuration:

- WIND 3100 unit with protective cover.
- Masthead unit.
- 30 m Masthead cable.
- Masthead cable junction box.
- Warranty card.
- Mounting template.
- *This Installation and Operation Manual.*



### 7-2 Other parts required

One or more 3100 series instruments will be connected to the boat 12 V DC power supply via:

- An accessory switch to turn the instruments on and off.
- A fuse. Use a 1 A fuse for between one and five instruments.

Optional external beepers or lights can be fitted. The WIND 3100 output is switched to ground, 30 V DC and 250 mA maximum. If the beepers and lights require more than 250 mA, fit a relay.

For systems of several instruments, wiring and connectors are required (see section 6 or the NavBus Installation and Operation manual).

In order to display true wind speed and direction and VMG, the WIND 3100 must be connected to an instrument that outputs speed (see section 6).

The WIND 3100 is usually used with the supplied masthead unit. However, the unit can take readings from another NAVMAN wind instrument, in which case the masthead unit does not need to be fitted (see section 6-1).



### 7-3 Accessories

These accessories are available from your NAVMAN dealer.



Replacement masthead unit



Masthead unit windcup



NavBus junction box (see section 6)

## 8 Installation and setup

Correct installation is critical to the performance of the unit. It is vital to read this section of the manual and the documentation that comes with the other parts before starting installation.

The WIND 3100 can:

- Drive external beepers or lights for the alarm.
- Send and receive data from other NAVMAN instruments connected via NavBus. Settings for alarms, units, calibration and backlighting are shared (see section 6-1).
- Send and receive NMEA data to and from other instruments (see section 6-2).

### Warnings

The unit is waterproof from the front. Protect the rear of the unit from water, or else water might enter the breathing hole and damage the unit. The warranty does not cover damage caused by moisture or water entering the back of the unit.

The cable up the mast to the masthead unit must run in conduit.

**Ensure that any holes that you cut will not weaken the boat or the mast. If in doubt, consult a qualified boat builder or marine engineer.**

### 8-1 Installation

#### WIND 3100 display unit

- 1 Choose a location for the display unit that is:
  - Easily seen and protected from damage.
  - At least 100 mm from a compass and at least 500 mm from a radio or radar antenna.
  - Away from engines, fluorescent lights, and power inverters.
  - Accessible from behind; the minimum clearance required at the back is 50 mm (2") (see mounting diagram).
  - With the back of the unit protected from moisture.
- 2 The unit must mount on a flat panel which is less than 20 mm (0.75") thick. Stick the mounting template in place. Drill a 50 mm (2") fixing hole through the centre hole in the template. Note that the template allows space around the unit for the protective cover.
- 3 Remove the fixing nut from the back of the unit. Insert the stud at the back of the unit through the mounting hole. Hand tighten the fixing nut.

#### Side view of display unit mounting:

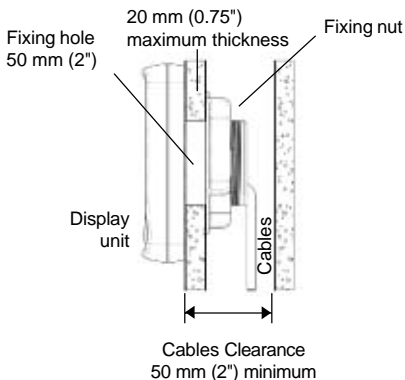

#### Masthead unit

Plan the installation. Read through these instructions before you install the masthead unit and plan where you will fit the mounting block and where you will drill the cable holes in the mast. It is usually easiest to install the masthead unit when the rig is off the boat.

- 1 The mounting block is at one end of the 30 m (90 ft) masthead cable. Fit the mounting block on top of the mast:
  - With the base of the block horizontal.
  - With the fitting for the masthead arm facing forward, parallel to the centre line to within a few degrees (if the arm does not face exactly forward, the wind direction will need to be aligned, see section 3-4).

Use the self-tapping screws provided.

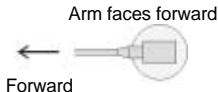

- 2 Drill an 8 mm (5/16") hole at the top of the mast close to the mounting block for the cable to enter the mast. Do not install the masthead cable yet.
- 3 Drill an 8 mm (5/16") hole at the bottom of the mast at a convenient place for the cable to exit the mast. You will fit the cable junction box close to this hole; it should be in a dry place and not in the bilge.
- 4 Calculate how long the cable from the masthead mounting block to the cable junction

box needs to be. Allow extra length for terminating the cable in the junction box. Cut the masthead cable to this length from the mounting block. Do not throw away the other piece of cable.

- 5 Lead the bare end of the masthead cable into the hole at the top of the mast, down the conduit in the mast and out the hole at the bottom of the mast. Fit a strain relief clamp or cable tie to the cable at the mast top. Fill both cable holes in the mast with sealant.
- 6 Feed the end of the cable through a gland on the cable junction box. Strip the cable jacket off and terminate the wires on the terminal block supplied.
- 7 Take the piece of masthead unit cable that you cut off earlier and connect the cable into the back of the WIND 3100 display unit. Run the cable between the display unit and the cable junction box:
  - Keep the cable away from other cables, engines, fluorescent lights and power inverters
  - Secure the cable at regular intervals.
- 8 Cut the cable to length, allowing extra length for terminating the cable in the joining box. Feed the end of the cable through the other gland on the cable junction box. Strip the cable jacket off and terminate wires on the terminal block, matching the wire colours.
- 9 Screw the lid on the junction box and screw the box in place on a panel.
- 10 Fit the wind cups to the shaft on the masthead unit using the allen key supplied.

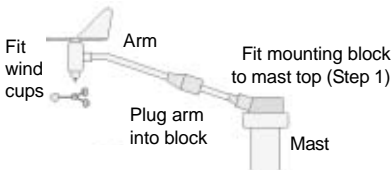

- 11 Attach the arm to the mounting block:
  - Plug the arm into the mounting block.
  - Screw the sleeve on the arm onto the mounting block.

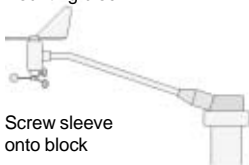

## Installed Masthead Unit:

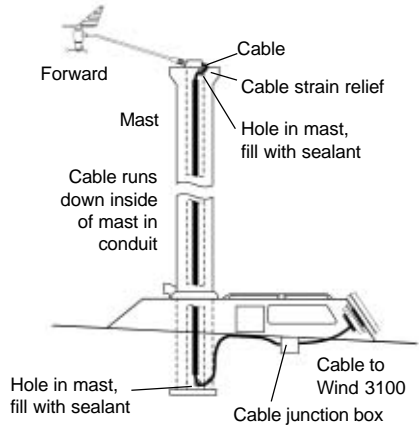

## Power/data wiring

- 1 Wire the display unit power/data cable:
  - The unit requires 12 V DC power. Fit a power switch and fuse to the power supply or power the unit from a fused auxiliary switch. The fuse should be 1 A for up to five instruments.
  - If the external beepers and lights require more than 250 mA DC total, fit a relay.

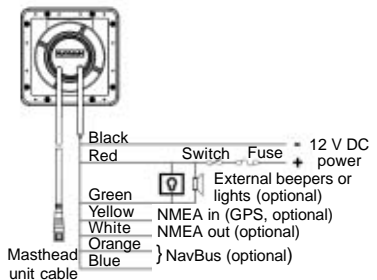

A single unit can be wired as shown below:  
 With several instruments, use the optional junction boxes to simplify wiring, as shown below:

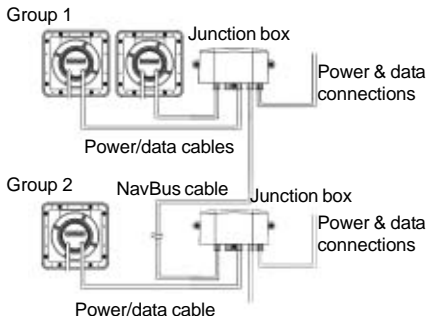

For information on how to connect NavBus and to use junction boxes, refer to the NavBus Installation and Operation manual.

- 2 Tape or cover any unused wires or connectors to protect them from water and keep them from shorting together.

## 8-2 Setup

- 1 Take the boat for a trial run to check that all the instruments work correctly.
- 2 To display VMG, true wind speed and direction, the WIND 3100 must be connected to an instrument that outputs boat speed. If the WIND 3100 is connected to an instrument that outputs speed through water and to an instrument that outputs speed over ground, then you can select which the WIND 3100 will use (see sections 3-1 and 6):



- i Press **Q** + **V** several times until the Speed Mode screen is displayed:



- ii Press **^** or **v** to change the mode to **Gr** (Speed over ground) or **ba** (boat speed through water).
- iii Press **Q**.
- 3 If the unit is part of a system of 3100 series instruments connected by NavBus, set the backlight group number (see section 6-1):
  - i Press **Q** + **V** several times until the Backlight Group screen is displayed:
  - ii Press **^** or **v** to set the backlight group number.
  - iii Press **Q**.
- 4 Set:
  - The speed units (see section 4-1) .
  - The pointer type (see section 3-2).
- 5 Calibrate if required:
  - Wind alignment (see section 3-4).
  - Wind speed (see section 4-4).

## 8-3 Resetting to factory defaults

All settings may be reset to the manufacturer's default settings (see below).

Wind speed units .....	knots
Pointer type .....	1
Direction damping .....	2
Steering angle .....	40°
Steer angle resolution .....	2° per segment
Wind speed alarm .....	Off
SIMULATE mode .....	Off
Backlight Level .....	0
Backlight Group .....	1
Boat Speed Input .....	ba

To reset to factory defaults:

- 1 Turn the power off.
- 2 Hold down **Q** + **v** while you turn the power on and continue to hold the keys down for at least five seconds.

## Appendix A - Specifications

### Physical

- Case size 111 mm (4.4") square.
- LCD display 82 mm (3.2") wide, 61 mm (2.4") high; twisted nematic.
- LCD digits 30 mm (1.2") high on top line, 20 mm (0.8") high on bottom line.
- Four operator keys, laser etched.
- Backlighting for display and keys, amber, four levels and off (the key backlight does not turn off).
- Operating temperature 0 to 50°C (32 to 122°F).
- Power Cable length 1m (3.25 ft).
- Masthead unit cable length 30 m (99 ft).

### Electrical

- Power supply 10.5 to 16.5 V DC, 20 mA without backlighting, 120 mA with full backlighting and transducer.
- External beeper or light output, switched to ground, 30 V DC and 250 mA maximum.

### Wind

- Wind direction, true and apparent: Range 0 to 180°, port or starboard.
- Wind speed, true and apparent: Range 0 to 199 knots (0 to 102 m/s).
- Maximum apparent wind speed.
- Apparent wind speed alarm.

### Calibration

- Wind speed and wind direction (alignment) can be calibrated.

### Interfaces

- NavBus connection to other NAVMAN instruments.
- NMEA 0183 outputs: MWV, VPW; inputs RMC, VHW, VTG.

### Standards compliance

- EMC compliance
  - USA (FCC): Part 15 Class B.
  - Europe (CE): EN50081-1, EN50082-1
  - New Zealand and Australia (C Tick): AS-NZS 3548.
- Environment: IP66 from front when correctly mounted.

### Power/data cable wires

Wire	Signal
Red	Power positive, 12 V DC, 120 mA maximum
Black	Power negative, NMEA common
Green	External beeper or light out, switched to ground, 30 V DC and 250 mA max.
Orange	NavBus +
Blue	NavBus -
White	NMEA out
Yellow	NMEA in

## Appendix B - Troubleshooting

This troubleshooting guide assumes that you have read and understood this manual.

It is possible in many cases to solve difficulties without having to send the unit back to the manufacturer for repair. Please follow this troubleshooting section before contacting the nearest NAVMAN dealer.

There are no user serviceable parts. Specialized methods and testing equipment are required to ensure that the unit is reassembled correctly and is waterproof. Repairs to the unit must only be carried out by a service centre approved by Navman NZ Limited. Users who service the unit themselves will void the warranty.

More information can be found on our website: [www.navman.com](http://www.navman.com)

### 1 Unit will not turn on:

- a Fuse blown or circuit breaker tripped.
- b Battery voltage is outside the range 10.5 to 16.5 V DC.
- c Power/data cable damaged.

### 2 Wind speed or direction readings wrong or erratic:

- a Wind speed calibration is incorrect (see section 4-4).
- b Wind direction alignment is incorrect (see section 3-4).
- c Masthead unit cable unplugged or damaged.
- d Masthead unit is damaged or fouled.
- e Interference from electrical noise. Review installation.

### 3 The word SIM flashes at top, right of screen, values displayed are unexpected:

- a Unit is in simulate mode (see section 2-4).

### 4 The display fogs:

- a Moist air has entered the breathing tube at the rear of the unit. Air the boat or run unit with backlight fully on.
- b Water has entered the breathing tube. Return unit for service.



**NORTH AMERICA****NAVMAN USA INC.**

18 Pine St. Ext.

Nashua, NH 03060.

Ph: +1 603 577 9600

Fax: +1 603 577 4577

e-mail: sales@navmanusa.com

**OCEANIA****New Zealand****Absolute Marine Ltd.**Unit B, 138 Harris Road,  
East Tamaki, Auckland.

Ph: +64 9 273 9273

Fax: +64 9 273 9099

e-mail:

navman@absolutemarine.co.nz

**Australia****NAVMAN AUSTRALIA PTY**

Limited

Unit 6 / 5-13 Parsons St,

Rozelle, NSW 2039, Australia.

Ph: +61 2 9818 8382

Fax: +61 2 9818 8386

e-mail: sales@navman.com.au

**SOUTH AMERICA****Argentina****HERBY Marina S.A.**

Costanera UNO,

Av Pte Castillo Calle 13

1425 Buenos Aires, Argentina.

Ph: +54 11 4312 4545

Fax: +54 11 4312 5258

e-mail:

herbymarina@ciudad.com.ar

**Brazil****REALMARINE**

Estrada do Joa 3862,

CEP2611-020,

Barra da Tijuca, Rio de Janeiro,

Brasil.

Ph: +55 21 2483 9700

Fax: +55 21 2495 6823

e-mail:

vendas@marinedepot.com.br

Equinautic Com Imp Exp de

Equip Nauticos Ltda.

Av. Diario de Noticias 1997 CEP

90810-080, Bairro Cristal, Porto

Alegre - RS, Brasil.

Ph: +55 51 3242 9972

Fax: +55 51 3241 1134

e-mail:

equinautic@equinautic.com.br

**ASIA****China**

Peaceful Marine Electronics Co. Ltd.

Hong Kong, Guangzhou,

Shanghai, Qindao, Dalian.

E210, Huang Hua Gang Ke Mao

Street, 81 Xian Lie Zhong Road,

510070 Guangzhou, China.

Ph: +86 20 3869 8784

Fax: +86 20 3869 8780

e-mail:

sales@peaceful-marine.com

Website:

www.peaceful-marine.com

**Korea**

Kumho Marine Technology Co. Ltd.

# 604-816, 3F, 1117-34,

Koejung4-Dong, Saha-ku

Pusan, Korea

Ph: +82 51 293 8589

Fax: +82 51 294 0341

e-mail: info@kumhomarine.com

Website:

www.kumhomarine.com

**Malaysia**

Advanced Equipment Co.

43A, Jalan Jejaka 2, Taman

Maluri, Cheras 55100, Kuala Lumpur.

Ph: +60 3 9285 8062

Fax: +60 3 9285 0162

e-mail: ocs@pc.jaring.my

**Singapore**

RIQ PTE Ltd.

Blk 3007, Ubi Road 1,

#02-440, Singapore 408701

Ph: +65 6741 3723

Fax: +65 6741 3746

HP: +65 9679 5903

e-mail: riq@postone.com

**Thailand**

Thong Electronics (Thailand)

Company Ltd.

923/588 Thaprong Road,

Mahachai,

Muang, Samutsakhon 74000,

Thailand.

Ph: +66 34 411 919

Fax: +66 34 422 919

e-mail: thong@cscoms.com

**Vietnam**

Haidang Co. Ltd.

16A/A1E, Ba thang hai St.

District 10, Hochiminh City.

Ph: +84 8 86321 59

Fax: +84 8 86321 59

e-mail:

sales@haidangvn.com

Website: www.haidangvn.com

**MIDDLE EAST**

Lebanon and Syria

Petrol, Balco Stores,

Moutran Street, Tripoli

VIA Beirut.

Ph: +961 6 624512

Fax: +961 6 628211

e-mail: balco@cyberia.net.lb

United Arab Emirates

Kuwait, Oman &amp; Saudi Arabia

AMIT, opp Creak Rd.

Baniyas Road, Dubai.

Ph: +971 4 229 1195

Fax: +971 4 229 1198

e-mail: mksq99@email.com

**AFRICA**

South Africa

Percet (Pty) Ltd Coastal,

Division No.16 Paarden Eiland Rd.

Paarden Eiland, 7405

Postal Address: PO Box 527,

Paarden Eiland 7420

Cape Town, South Africa.

Ph: +27 21 511 5055

Fax: +27 21 511 5022

e-mail: info@kfa.co.za

**EUROPE**

France, Belgium and

Switzerland

PLASTIMO INTERNATIONAL

15, rue Ingénieur Verrière,

BP435,

56325 Lorient Cedex.

Ph: +33 2 97 87 36 36

Fax: +33 2 97 87 36 49

e-mail: plastimo@plastimo.fr

Website: www.plastimo.fr

Germany

PLASTIMO DEUTSCHLAND

15, rue Ingénieur Verrière

BP435

56325 Lorient Cedex.

Ph: +49 6105 92 10 09

+49 6105 92 10 10

+49 6105 92 10 12

Fax: +49 6105 92 10 11

e-mail:

plastimo.international@plastimo.fr

Website: www.plastimo.de

Italy

PLASTIMO ITALIA

Nuova Rade spa, Via del Pontasso 5

I-16015 CASELLA SCRIVIA (GE).

Ph: +39 1096 8011

Fax: +39 1096 8015

e-mail: info@nuovarade.com

Website: www.plastimo.it

Holland

PLASTIMO HOLLAND BV.

Industrieweg 4,

2871 JE SCHOONHOVEN.

Ph: +31 182 320 522

Fax: +31 182 320 519

e-mail: info@plastimo.nl

Website: www.plastimo.nl

United Kingdom

PLASTIMO Mfg. UK Ltd.

School Lane - Chandlers Ford

Industrial Estate,

EASTLEIGH - HANTS S053 ADG.

Ph: +44 23 8026 3311

Fax: +44 23 8026 6328

e-mail: sales@plastimo.co.uk

Website: www.plastimo.co.uk

Sweden, Denmark or Finland

PLASTIMO NORDIC AB.

Box 28 - Lundenvägen 2,

47321 HENAN.

Ph: +46 304 360 60

Fax: +46 304 307 43

e-mail: info@plastimo.se

Website: www.plastimo.se

Spain

PLASTIMO ESPAÑA, S.A.

Avenida Narcís Monturiol, 17

08339 VILARSAR DE DALT,

(Barcelona).

Ph: +34 93 750 75 04

Fax: +34 93 750 75 34

e-mail: plastimo@plastimo.es

Website: www.plastimo.es

Other countries in Europe

PLASTIMO INTERNATIONAL

15, rue Ingénieur Verrière

BP435

56325 Lorient Cedex, France.

Ph: +33 2 97 87 36 59

Fax: +33 2 97 87 36 29

e-mail:

plastimo.international@plastimo.fr

Website: www.plastimo.com

REST OF WORLD /

MANUFACTURERS

NAVMAN NZ Limited

13-17 Kawana St. Northcote.

P.O. Box 68 155 Newton,

Auckland, New Zealand.

Ph: +64 9 481 0500

Fax: +64 9 480 3176

e-mail:

marine.sales@navman.com

Website:

www.navman.com

Made in New Zealand  
MN000134 1951320B

Lon 174° 44.535'E

Lat 36° 48.404'S

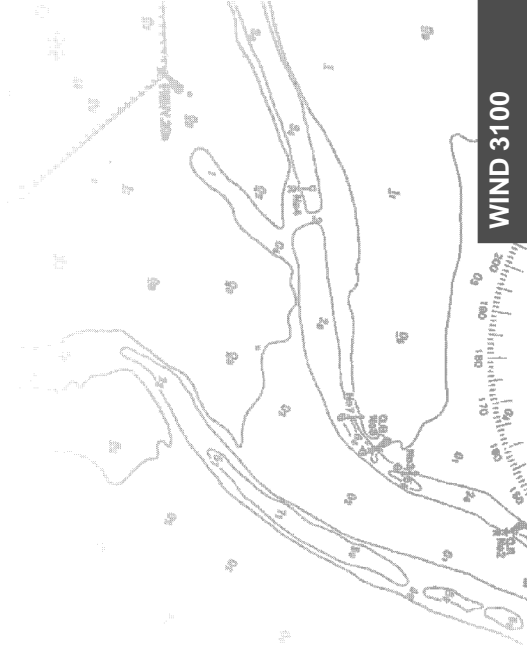

WIND 3100

# NAVMAN

FC  CE